



LabelLase[®] 28XX Tag Printer
Basic Operations & Maintenance Manual
LL2860, LL2886, LL28100



Revision E
February 2021

INFOSIGHT CORPORATION

20700 U.S. Highway 23

P.O. Box 5000

Chillicothe, Ohio 45601 USA

+1.740.642.3600 Tel. (M-F 8am-5pm US Eastern Time Zone)

+1.800.401.0716 Emergency Service U.S. & Canada (outside normal business hours)

+1.740.642.4666 Emergency Service International (outside normal business hours)

+1.740.642.5001 Fax.

www.infosight.com

This page intentionally left blank

Manual Revision History:

10/09/2007	Revision A	Initial Release
10/15 /2007	Revision B	Correction to Spares List - ITM24343 Added Manual Revision History
12/13/2012	Revision C	Common Setup Printer Configuration Values Added Clarification to 120/240VAC and Labeling
5/1/2013	Revision C2	Added Floor Mount Instructions Added Fuse Replacement Clarification
5/21/2013	Revision C3	Changed laser safety wattages
5/22/2013	Revision C5	Cleaned up the index
10/15/2013	Revision C6	Added 80 Watt Laser
3/14/2014	Revision C7	Added 100 Watt Laser
3/18/2016	Revision D	Updated for Producer Upgrade, updated formatting
9/16/16	Revision D1	Corrections after Reviews
10/1/2019	Revision D2	Corrections after Reviews Corrections Laser Settings Table Added 60 Watt Laser Specifications Correct Block diagram
01/18/21	Revision E	Remove old printer models no longer offered Update with currently offered printer models

COPYRIGHT

Copyright © 2003-2021 INFOSIGHT CORPORATION
All rights reserved, Printed in U.S.A.

First Printing: August 2003

INFOSIGHT CORPORATION reserves the right to make changes in specifications and other information contained in this manual without prior notice, and the reader should consult INFOSIGHT CORPORATION to determine whether any such changes have been made.

In no event shall INFOSIGHT CORPORATION be liable for any incidental, indirect, special, or consequential damages whatsoever (including but not limited to lost profits) arising out of, or relating to this manual or the information contained in it, even if INFOSIGHT CORPORATION has been advised, knew, or should have known of the possibility of such damages.



INFOSIGHT CORPORATION expressly warrants the equipment manufactured by it as set forth in the Standard Terms and Conditions of Sale. INFOSIGHT CORPORATION makes no other warranties, either expressed or implied (including without limitation warranties as to merchant ability or fitness for a particular purpose).

InfoTag[®], Labelase[®], PermaLabel[®], Pic-Anneal[®], and KettleTag[®]PLUS are registered trademarks of InfoSight Corporation.

Labelase[®] Producer[™], Info-Tint[™], FoamTag[™], ToughTag[™], AlumaTag[™], and X-Tag[™] are trademarks of InfoSight Corporation.

Windows[®] is a registered trademark of Microsoft Corporation.

Optical/Laser Safety

	<p>INVISIBLE LASER RADIATION AVOID EYE OR SKIN EXPOSURE TO DIRECT OR SCATTERED RADIATION CLASS 1 LASER PRODUCT, USING A CLASS 4 EMBEDDED LASER (60W, 80W, or 100W, 10.57 – 10.63 μm)</p> <p><i>The laser beam Exits the Final lens 7.5 inches from the tag</i></p>
	<p><i>Never attempt to operate the Laser Tag Marker without the protective covers in place.</i> <i>Never attempt to override any of the safety interlocks on the tag printer.</i> <i>Never attempt to dismantle or repair the tag printer. In case of malfunction contact a Infosight service representative.</i> <i>Any of the actions mentioned above may result in permanent eye or skin damage. Refer to Laser Safety section for more information on laser safety.</i></p>

Labels / Warnings

	<p>Caution, Laser Radiation – See Appendix</p>
	<p>Warning label located on the side on the maintenance door and on the top in front of the exhaust:</p> <p>CLASS 4 INVISIBLE LASER RADIATION WHEN OPEN AVOID EYE OR SKIN EXPOSURE TO DIRECT OR SCATTERED RADIATION</p>
	<p>Warning label located above the rating plate on the side of the Laser Marker, near the bottom, near the communications ports:</p> <p>CLASS 1 LASER PRODUCT</p>
<p>Environmental Conditions</p>	<p>The LabeLase® Printer is intended for Indoor use only. Altitude up to 6500 feet, operating temperature 40 to 100 degrees F, 80% maximum relative humidity, rated 220VAC Fused at 5A 50/60Hz or 110VAC fused at 12A 50/60Hz according to Job Number (Legend plate on marker), pollution degree 2. NOTE: 220V models both sides of the incoming line voltage are fused.</p>
<p>CAUTION</p>	<p>If this printer is not used in the manner specified by this manual, the safety features provided may be insufficient.</p>
	<p>Warning Label located on the side of the printer, near the communications ports, regarding California Proposition 65.</p>

SOFTWARE/FIRMWARE LICENSE AGREEMENT

IMPORTANT: THE SUBJECT PROGRAMS ARE LICENSED BY INFOSIGHT CORPORATION TO END-USERS FOR THEIR USE ONLY ON THE TERMS BELOW. ACCEPTING AND USING THESE PROGRAMS INDICATES YOUR ACCEPTANCE OF THESE TERMS. THIS IS A LEGAL AGREEMENT BETWEEN YOU, THE END USER, AND INFOSIGHT CORPORATION.

- 1) GRANT OF LICENSE. INFOSIGHT CORPORATION ("INFOSIGHT") agrees to grant to you a non-exclusive license to use the INFOSIGHT software/firmware program (the "PROGRAM") subject to the terms and conditions of this license agreement.
- 2) DEFINITION OF TERMS. The term SOFTWARE refers to a computer program stored on CDROM, floppy diskette, hard disk, magnetic tape, paper tape or other media, that must be loaded into the computer's memory to be executed. The term FIRMWARE refers to a computer program stored in semiconductor memory (ROM, PROM, EPROM, EEPROM, NVRAM, etc.) that is an integral part of the computer's memory. Together, these forms of computer programs are referred to as the "PROGRAM".
- 3) COPYRIGHT. The PROGRAM(s) and Documentation are owned by INFOSIGHT and are protected by United States copyright laws and international treaty provisions. The PROGRAM(s) contain trade secrets and proprietary property of INFOSIGHT. You may make one copy of the PROGRAM(s) solely for backup or archival purposes provided that the copy clearly displays the INFOSIGHT copyright notice. Additional copies may be made when authorized to do so in writing by INFOSIGHT. In addition to any other right of INFOSIGHT, INFOSIGHT has the right to terminate this license if the terms of this license are violated.
- 4) RESTRICTION ON USE AND TRANSFER. The single-processor version(s) of the PROGRAM(s) and Documentation are to be used on one computer or embedded system at any one time. The multi-processor version(s) of the PROGRAM(s) and Documentation may be used over a network provided that the number of computers accessing the network simultaneously shall not exceed the number authorized by INFOSIGHT or for which you paid the corresponding multi-processor fee. You may not distribute the PROGRAM(s) or Documentation to a third party. You may transfer the license and complete package (retaining nothing) if the transferee agrees to the terms of this License Agreement. Neither the PROGRAM(s) nor the Documentation may be changed or translated without express written permission of INFOSIGHT. You may not reverse engineer, decompile or disassemble the PROGRAM(s).
- 5) WARRANTY for the subject PROGRAM(s) is covered under the INFOSIGHT STANDARD TERMS AND CONDITIONS OF SALE.
- 6) TERM. The license is effective until terminated. It may be terminated if you fail to comply with any term or condition of this License Agreement. You may terminate this License Agreement at any time. In the event of termination, you agree to destroy the PROGRAM(s) and Documentation together with all copies and related material.
- 7) YOUR USE OF THIS PROGRAM(S) acknowledges that you have read this License Agreement and agree to its terms. This agreement is complete and supersedes any other agreement that may have related to the subject matter of this agreement.

PREFACE

The LabelLase® 28XX Tag Printer is fourth in the family of InfoSight laser tag markers. The LabelLase® 28XX series contains many new features, including: a higher internal processor clock speed, a PC-driven interface and the ability to print multilingual fonts.

This OPERATIONS AND MAINTENANCE manual is intended as a companion to the ONLINE REFERENCE MANUAL supplied with the Producer™ & Designer software package and also available on the InfoSight webpage:

<http://www.infosight.com/labelaseproducer2/>

This OPERATIONS AND MAINTENANCE manual will be automatically installed on your computer hard drive when installing the Producer™ software from the thumbdrive. It may be found under the PROGRAMS menu with other INFOSIGHT software and HELP files.

MINIMUM SYSTEM REQUIREMENTS

- IBM PC 100% compatible computer.
- Windows 7 (32/64bit) / Windows 8/8.1 (32/64 bit) / Windows 10 (32/64 bit)
- 1 Serial Com port, USB port, or Ethernet port (for connection to the printer).
- Color monitor (1024X768 resolution or higher recommended) .

This page intentionally left blank.

Table of Contents

SYSTEM STARTUP	1
AFFIXING THE LL28XX TO SOLID PLATFORM.....	1
CONNECT WATER COOLER TO PRINTER	2
STARTUP SEQUENCE:	3
LOADING NEW TAGS	4
PRINTING A TAG	5
LABELASE® PRODUCER™ SOFTWARE	6
PRINTER CONFIGURATION & LASER SETTINGS.....	7
COMMON SETUP PRINTER CONFIGURATION VALUES FOR VARIOUS MODELS	7
CYCLE TIME CONSIDERATIONS.....	8
BASIC TROUBLE SHOOTING	9
NORMAL MAINTENANCE & SERVICING	10
SIDE AIR FILTER REMOVAL & REPLEMENT	10
CUSTOMER SERVICE	11
FUNCTIONAL BLOCK DIAGRAM.....	12
RECOMENDED SPARES FOR LL28XX.....	13
LASER SAFETY.....	14
Section I: Introduction to Laser Safety	14
Section II: Types of safety interlocks.	14
Internal Laser Specifications (60 Watt)	15
Internal Laser Specifications (80 Watt)	16
Internal Laser Specifications (100 Watt)	17
LASER SPECIFICATIONS:.....	17
DECLARATION OF CONFORMITY	18
ENGINEERING DRAWINGS	20

This page intentionally left blank.

SYSTEM STARTUP

The Power requirements for the Labelase® 28XX Tag Printer differs according to the as built customer requirement. By looking at the label plate at near the power entry you can determine whether the unit is:

- 120 VAC, 50/60HZ fused at 10 Amps *or*
- 240 VAC, 50/60 Hz, fused at 5 Amps.

WARNING: 220V models both sides of the incoming line voltage are fused.

Recommended AC plug type is :
Woodhead 1447 for 110V

Use a properly approved IEC 309 plug for 220V power connection.

Note: Complete AC Disconnect is accomplished at the power plug.

The Labelase® 28XX Tag Printer should be positioned so that the power supply cord exits from the left side of the machine.

The Labelase® 28XX Tag Printer should be placed in a temperature controlled environment. This marker, though designed for industrial use, should be treated as any typical computer system and printer. Dirty environments will necessitate more frequent cleaning for internal optics.

A 12-foot (3.6 meter) RS-232 serial communications cable and a USB communications cable are provided for communicating with your Windows-based PC. Use only one cable.

AFFIXING THE LL28XX TO SOLID PLATFORM

Important:

The LL28XX support legs are designed to be anchored to the floor or concrete to prevent the unit from tipping over in the unlikely event of a force exerted upon the side surfaces of the units. Incorporated in the design of the support legs are 4 x 33/64" thru-holes. These four thru-holes are to have placed through them, suitable anchor bolts to affix the LL28XX to the floor. The type of anchor bolt used will depend upon the base material the LL28XX will be set upon. Recommended anchor bolts are listed below.

Note: Anchor bolts used are to withstand a tension weight of at least 50 lbs. each.

Manufacture	Description	Floor type
Hilti	KB II 38-3 3/8" Kwik bolt	Concrete
	Cast in place 3/8-16UNC 2"	Concrete
	3/8" x 2" Lag bolts	Wood
	3/8" x 4" J bolts	Steel Grating

CONNECT WATER COOLER TO PRINTER

The printer needs to be connected to a water cooler. InfoSight recommends a CoolMate water cooler.

Connect the inlet and outlet water lines between the cooler and the printer. It does not matter which connection is which in the printer – the water will flow in either direction. The connection points are circled in the photo to the right. Note – the printer is shipped with a short tube connected to each connection point. This is to keep the connections and internal water lines clear.

Plug the cooler into an outlet. There is no automatic control between the printer and the cooler. The cooler needs to be running when the printer is. It is the operator's responsibility to ensure the cooler is running.



STARTUP SEQUENCE:

1. Attach the preferred communications cable from the LabeLase® 28XX Tag Printer to your Windows-based PC running LabeLase® Producer™ software.
2. Install tag stock onto tag payoff reel
3. Insert the AC power cord into a nearby power receptacle.
4. Place the security key in the machine, The key functions as an ON-OFF switch.
5. Turn key to the horizontal (ON) (I) position. NOTE: The security key can only be removed when in the OFF position.

Side Panel, toward the bottom

6. Remove E-STOP by pulling the red button.
7. Feed tag stock into printer. If necessary, press the tag FEED button to align tags to the breakoff location.
8. Start LabeLase® Producer™ software on your PC.
9. Load a pre-existing tag layout, or design a new tag layout. NOTE: designing or changing a tag layout requires SUPERVISOR login.
10. Adjust printer setup parameters if necessary (e.g., laser speed). NOTE: other than setting laser speed (LIGHTER/DARKER slider bar), this feature requires SUPERVISOR login.

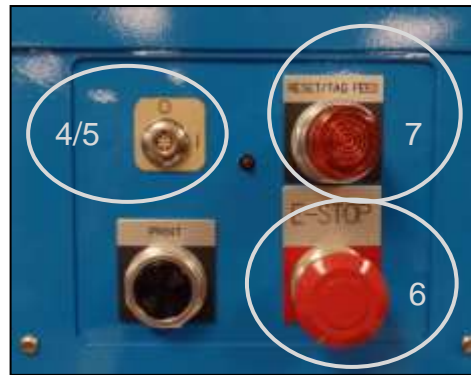
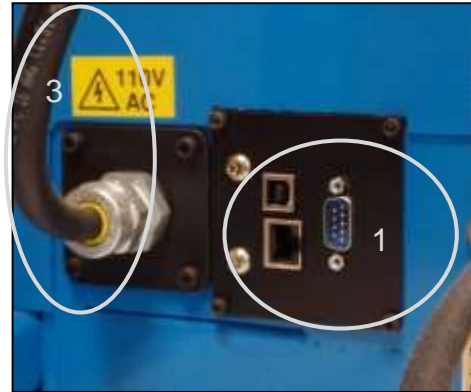

Front Panel

NOTE: The Producer™ software is password protected for all features beyond loading an existing tag layout, entering tag variable data, adjusting laser speed and initiating printing.

The default password for new installations is blank (no data, no spaces). A new password should be created before printer is commissioned for regular operator use.

LOADING NEW TAGS

CAUTION: DO NOT GRIP THE TAG STOCK BY ITS EDGES WHEN FEEDING INTO THE PRINTER. PROTECT YOUR HANDS AND FINGERS FROM THE SHARP EDGES OF THIN METAL TAG STOCK AT ALL TIMES.

1. Mount the new roll atop the circular platform to the left of the marker.
2. Feed by hand the tip of the tag stock, pushing it into first roller until it stops on “the drive roller”.
3. Once reaching the drive roller press the Amber Lighted Tag Feed Pushbutton.



Reminder - The marker is not ready for use and will not feed tags until the E-STOP button is returned to the OUT position by pulling red button.

If necessary, tag stock can be manually fed into the printer by pressing the FEED button located above the large red E-STOP button.

PRINTING A TAG

Note - The following assumes the LabelLase® 28XX Tag Printer has already been setup with a tag layout.

There are several ways to print a tag using the LabelLase® 28XX.

- A) If tag stock is loaded in the machine from the rear payoff reel and properly aligned at the break off exit point:
1. Pressing the **PRINT button** located beside the red E-STOP will initiate printing of 1 or more tags, depending on operator-entered data on the main Producer™ screen.
 2. Pressing the **F12 key** on your PC.
 3. Use the mouse to click **Accept** and **Begin Print** button on your PC.
 4. A **print command** may be sent from your host computer to your PC via Extended Protocol.
- B) If there is no tag stock feeding in from the side of the machine, a single tag inserted in the SIDE slot will be automatically drawn into the printer.
5. If the AUTO PRINT SINGLE ITEMS box is checked (enabled) in the SETUP / PRINTER CONFIGURATION menu (requires supervisor login), then **tag printing will begin automatically** with no further action or input required.
 6. If the auto print box is NOT checked, then any of the above methods in paragraph (A) may be used to initiate printing.

CAUTION: DO NOT GRIP THE TAG STOCK BY ITS EDGES WHEN FEEDING INTO THE PRINTER. PROTECT YOUR HANDS AND FINGERS FROM THE SHARP EDGES OF THIN METAL TAG STOCK AT ALL TIMES.

NOTE: The SINGLE PRINT feature of the printer requires a minimum tag or tag-strip length of three inches (76mm).

For example, a single 3x3 (or 3x4, 3x6, etc) tag may be printed. If single printing of a 3x1 (76 x 25mm) tag is desired, a strip of at least 3 tags must be inserted in the side slot.

LABELASE® PRODUCER™ SOFTWARE

LabeLase® Producer™ is an integrated, Windows-based application for complete control of tag design and printing. For complete details, please refer to the ONLINE REFERENCE MANUAL supplied with the software, or on the web at www.infosight.com/labelaseproducer3/.

Features:

The software has many features designed to provide maximum flexibility to serve the customer's specific marking needs. Some of these features include:

- Control up to four (4) printers
- Built-in and online (web access) HELP.
- Total freedom to change tag layout whenever needed.
- WYSIWYG (“What You See Is What You Get”) user interface for simple and intuitive tag design.
- New features emulating popular presentation software packages to speed layout and organization of complex designs containing multiple text and graphics fields.
- An unlimited number of data, text, barcode and graphics fields.
- Move fields easily with drag-and-drop.
- Rotate fields in 90-degree increments.
- Unlimited UNDO-REDO to easily correct mistakes.
- Optional placement grid with snap-to placement aid.
- Optional field anchor display shows field alignment.
- Zoom in/out for detailed display.
- Tag geometry features such as holes, slots, bare edges and bend lines can be shown.
- Prints all PC-installed fonts, including all Unicode compatible fonts.
- User-selectable download of message data from a host computer via RS-232, network TCP/IP, or network file transfer. A wide selection of communications protocols includes InfoSight Extended, emulation of Zebra and Intermec standard printers, and simple comma or tab-separated, flat-file formats. Details can be found in the communications chapter of the online reference manual.
- Operator entry of message data, for example if the host computer is unavailable.
- Easy control over printer setup parameters such as laser speed (i.e., formerly known as the “heat” setting for different types of laser tag material) and high/low pixel density (i.e., “draft” and “normal” printing modes)
- Auto-print feature for single tag printing (i.e., whenever a roll of tags is not loaded, a single tag can be auto-printed simply by inserting the tag in the front tag slot).
- Auto-incrementing of all text and number fields, for unattended batch printing.

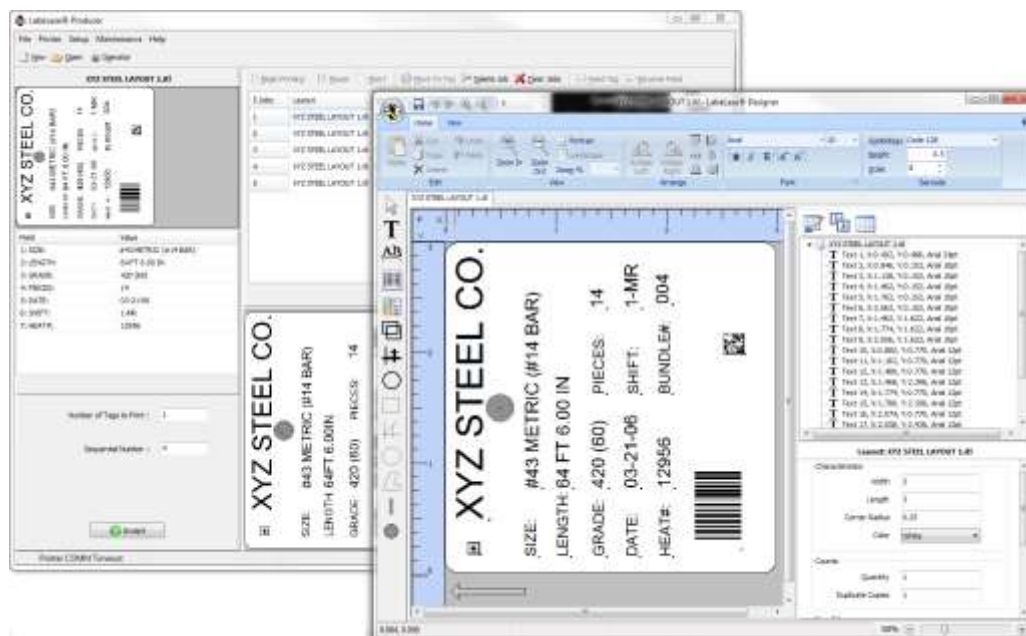

PRINTER CONFIGURATION & LASER SETTINGS

The LabeLase® 28XX printer and LabeLase® Producer™ software are designed with a high degree of flexibility and user-control, to enable the system to be used in a wide range of applications and on an ever-increasing array of laser-markable materials.

Calibration and configuration settings are accessed in LabeLase® Producer™ under SETUP-PRINTER/CONFIGURATION. On-line help instructions will guide you through each of the available settings. The most common parameters for fine-tuning the performance of the printer beyond the easy-to-use LIGHTER/DARKER SLIDER BAR are LASER SPEED, LASER OFF TICKLE, and LASER ON DUTY CYCLE, all of which are found under the LASER tab. Each of these parameters separately and together can be adjusted to create the right balance of black/white contrast, fineness of detail and cycle time.

As laser speed is increased printing cycle time will be faster.

NOTE: In general, as laser speed increases, duty cycle may also be increased to achieve the same relative blackness. Some materials with especially sensitive surfaces, such as PermaLabel®, will print more consistently at lower duty cycles, and therefore correspondingly lower laser speeds. Tickle controls the readiness of the laser to fire and helps maintain consistency of marking across the tag surface. Some tag materials are more sensitive to power variation than others, but in most cases this parameter can be left at its factory setting.

Each printer is calibrated in our factory before shipping. Copies of the configuration settings are shipped with each printer.

Experience has shown the following settings to be a good starting point for the most common types of tag material. Each individual application may then be fine tuned to achieve the right balance of cycle time, fineness of detail, and black/white contrast.

COMMON SETUP PRINTER CONFIGURATION VALUES FOR VARIOUS MODELS

	LL2860	LL2886	LL28100
Stepper Res	0.00514	0.00514	0.00514
Steps Per Rev	200	200	200
Usteps Per Co	1	1	1
Motor Min Freq	100	100	100
Motor Max Freq	1200	1200	1200
Reversing Takeup	0	0	0
Mirror Res	0.0052	0.0052	0.0052
Galvo Step Size	47	47	47
Galvo Start Marg	.5	.5	.5
Galvo End Marg	0	0	0
Galvo Home Delay	14	14	14
Galvo Offset	0	0	0
Laser Speed	80	100	150
Min Speed	10	20	30
Max Speed	120	150	200
Laser Off Tickle	7	7	7
Laser Duty Cycle	90	80	70
Num Lasers	1	1	1
Tear Off	7	7	7
Burn Loc	3.88	3.88	3.88

CYCLE TIME CONSIDERATIONS

Tag design and printer configuration can have a significant influence on cycle time. Here are a few techniques that, in many cases, can significantly speed printing.

1. Select DRAFT mode. When DRAFT mode is on, stepper and mirror resolution, laser speed, font sizes, and barcode and graphic scales are automatically adjusted to compensate.



2. Increase laser speed (move slider bar to LIGHTER).

3. Create darker easier-to-read characters by using BOLD font instead of a larger font size. ARIAL BLACK is an especially efficient font for creating easy-to-read text.



4. Design printing to run ACROSS the tag at 90° rotation (right angles to tag feed) rather than down the tag at 0° rotation (parallel to tag feed).



5. Avoid boxes or other graphics with long vertical (parallel to tag feed) lines.

6. Combine text into fewer lines. A single long line of text is more efficient than several short lines of text (at 90° rotation).

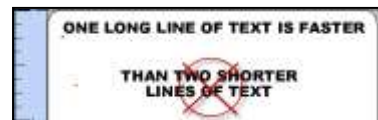

7. Keep graphics/logo X-scale and Y-scale factors equal to 1. If the graphic or logo must be re-sized to fit on the tag, use an external application such as MS PAINT to change the dimensions of the image and re-save the BMP file before importing into Producer™.



BASIC TROUBLE SHOOTING

Service during normal business hours (Monday-Friday, 8am-5pm): 888.642.3600 or 740.642.3600
Emergency after-hours service: +1.800.401.0716 (outside the USA call +1.740.642.4666)

Red LED Status Light:

- STEADY ON: ready to print.
- OFF: no power to laser (power cord, key switch, power switch).
- SLOW BLINK: out of tag stock.
- FAST BLINK: E-STOP.

Problem: Marker does not respond to print button.

- Check power cord.
- Check key switch.
- Check E-STOP.
- Check tag stock.
- Check serial cable to PC.
- Producer software must be running on the connected PC.
- Bottom of main Producer screen indicates printer status – “ONLINE”, “ESTOP” or “UNKNOWN MODE”. If UNKNOWN MODE, check communications cable and settings.
- From within Producer, click on HELP-ABOUT. If the FIRMWARE VERSION is blank, your PC does not see the printer. Check communications cable and settings.

Problem: Out of tag message on PC screen.

- Load more tag stock into printer.
- Insert single tag in side tag slot.

Problem: Tag exiting too far or not far enough (breakoff “nick” not aligned with exit slot).

- The printer may need to be re-calibrated. See the Troubleshooting & Maintenance / Feed and Tag Adjustment section of the built-in help.

Problem: Tag print appears very light, fine lines appear to drop out.

- Reduce laser speed (DARKER)
- Increase Laser Off Tickle (SETUP-PRINTER CONFIGURATION).
- Final output lens may require cleaning (see Maintenance section below).

Problem: Tag print shows “shadows”

- Decrease Laser Off Tickle (SETUP-PRINTER CONFIGURATION).

Problem: Tag print not aligned correctly with breakoff “nicks” (leading & trailing edges).

- Check that actual tag size in machine and programmed tag size in Producer (LAYOUT-SETUP-GEOMETRY) are the same.
- The printer may need to be re-calibrated. See the Troubleshooting & Maintenance / Feed and Tag Adjustment section of the built-in help.

Problem: Barcode too long for tag size.

- Reduce number of characters in barcode data.
- Use more efficient barcode symbology.
- Reduce barcode scale.

Problem: Blank Tag

- No layout loaded
- Laser overheated

NORMAL MAINTENANCE & SERVICING

Contact InfoSight for Training.

SIDE AIR FILTER REMOVAL & REPLACEMENT

The LabelLase® 28XX printer includes a light-duty foam filter element, intended for use in a normal office environment. It is not intended to protect the printer from industrial contaminants or vapors, typical of a factory or mill environment.

As the filter element accumulates dust and pollen over time, air flow through the printer may be reduced. This may cause excessive dust to accumulate on the internal optics (lenses and mirrors), which may shorten their life considerably. Therefore, it is important to monitor the condition of the filter and determine the appropriate cleaning frequency for your specific environment.

At high duty cycles when printing large batches of tags with a high percentage of black (printed) area, reduced air flow may also cause the internal temperature sensor to automatically shutdown the laser tube until it cools back to its normal operating temperature – this is normal.

The filter cover is located on the sides of the printer, and is held in place by snap on covers.

Carefully blow any lint or dust off the filter, or gently wash it in soap and water. Dry the filter thoroughly before reinstalling.

Be sure to replace the filter element into the cover plate correctly.



Figure 1 Side of LL28XX Printer shown with filter and cover in place (Left); with the filter and cover removed (Middle); and the filter and cover set aside (Right)

CUSTOMER SERVICE

How to reach customer service:

Phone Support	InfoSight Corporation Customer Service offers free phone support to answer questions during normal non-holiday working hours, Monday through Friday 8am to 5pm Eastern time (New York, USA). Call +1.888.642.3600, or outside the USA call +1.740.642.3600.
Emergency Service	After regular business hours, call: +1.800.401.0716 (USA or Canada) or +1.740.642.4666 (International).
On-Site Service	InfoSight Corporation can dispatch a Field Service Engineer to your facility to perform equipment start-up, repair, maintenance, and training.
Service Contracts	Periodic scheduled on-site maintenance, technical service and extended warranties can be arranged by contacting Customer Service at the number below.
Factory Service	Call Customer Service for a Return Authorization Number before returning equipment to our factory for repair and/or major maintenance.

For more information regarding any of these services, call +1.888.642.3600 (outside the USA call +1.740.642.3600) and ask for Customer Service.

Or, visit us on the worldwide web at www.infosight.com

FUNCTIONAL BLOCK DIAGRAM

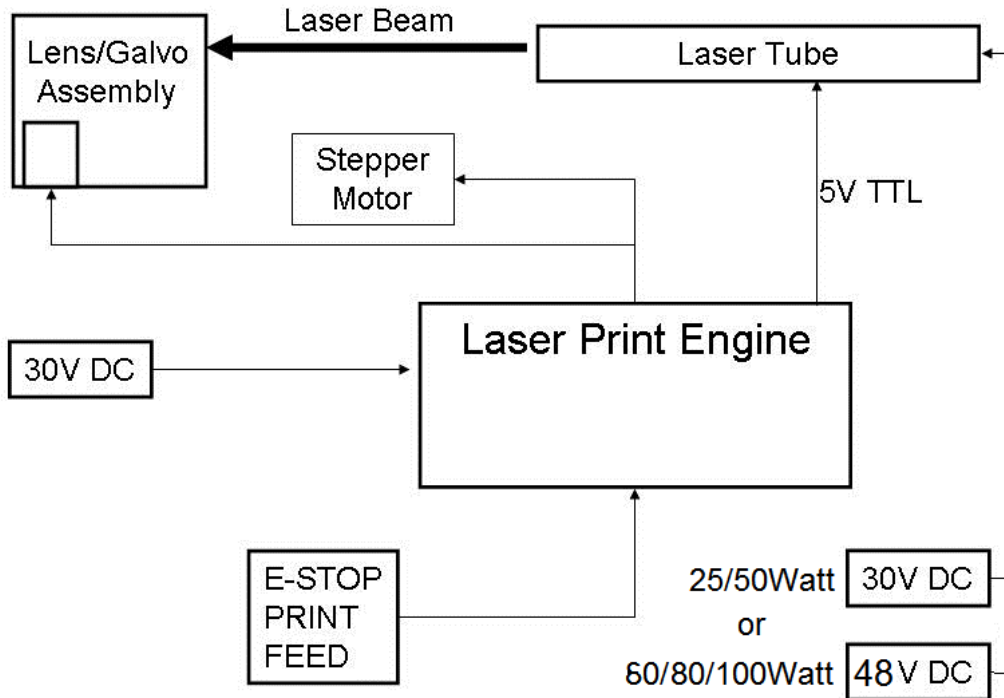

SERIAL PORT CONNECTION

Labelase® 28XX Serial port connection to an IBM-PC or equivalent.

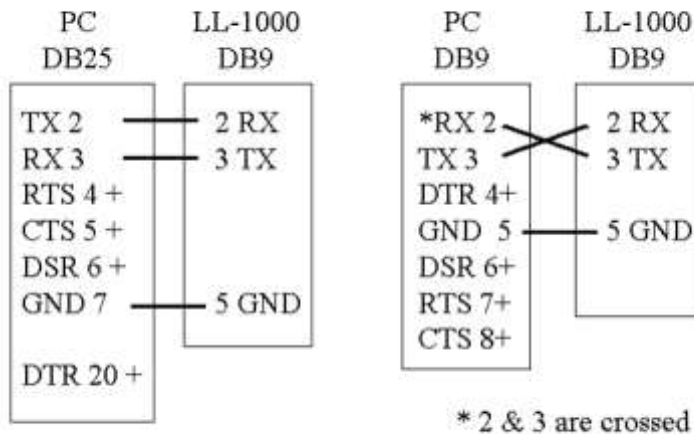

Note: Handshake protocol is XON / XOFF. Communications adapters such as USB to RS232 must support XON / XOFF.

XON is DC1 CTL-Q or 11h or 17 decimal
 XOFF is DC3 CTL-S or 13h or 19 decimal

RECOMENDED SPARES FOR LL28XX

**Break down of required spares for LL28xx by symptom
(Contact Factory for current pricing)
(01/21)**

PART#	DESCRIPTION	QTY
Tag slipping or not coming to breakoff correctly		
ITM18381	GEAR,DRIVE,KE28XX,32P,60TEETH,48RC,CARBON STEEL HEAT-TREATED	1
ITM18382	GEAR,DRIVE,KE28XX,32P,24TEETH,48RC,CARBON STEEL HEAT TREAT	1
ITM06436	ROLLER,DRIVE,1.625"DIA X 1/2"WIDTH	1
ITM08860	ROLLER,IDLER,1.625"DIA X 1/2"WIDTH	1
ITM06625	RING,RETAINING,FOR 3/8DIA SHAFT	2
ITM23574	SENSOR,OPTICAL,SLOTTED,WIDE GAP ROHS COMPLIANT	1
ITM15050	KIT,MOTOR,STEPPER/DRIVER,FOR 110/220V LASER MARKER CE APPROVED	1
Weak print- Laser rebuild or 30VDC supply ITM14840(See Below)		
ITM07560	LENS,1.1",DIA X 7.5" FOCAL LENGTH,PLANO CONVEX	1
ITM07199	MIRROR,ASSEMBLY,SCANNING,LASER	1
Dead		
ITM24891	POWER-SUPPLY,LASER,30V,16A,CE MARKED, ROHS COMPLIANT	1
ITM07243	SWITCH,KEYLOCK,SECURITY	1
ITM01515	FUSE, TIME DELAY, 10Z, FNM10	1
Misc		
ITM10871	FILTER,REPLACEMENT,FOR ITM10870 GUARD,5/PK	2
ITM01213	FAN,MUFFIN,120VAC,14W,2900RPM,112CFM	1

(Please Request quote for the entire spares list.)

LASER SAFETY

04/23/03

Section I: Introduction to Laser Safety

Lasers, like arc welders, are sources of intense light that require certain precautions to insure a safe, comfortable and compliant working environment. This is especially true since the laser included in this marking equipment operates in the infrared (invisible) portion of the light spectrum. The enclosure surrounding the marking area is designed to prevent human exposure to the light emitted by the laser. The following information covers the procedures taken to design a safe, efficient environment for laser marking equipment.

Laser products are categorized into one of four classes based upon the power of the laser light that is accessible to any person during normal operation. These classes range from Class 1, the lowest class requiring no additional safeguards other than those provided by the manufacturer, to Class 4, the highest class that requires additional operator and working environment safeguards for safe operation.

Class 1 laser marking systems include enclosures integral to the workstation that are constructed to prevent human access to the laser beam. Class 1 systems are safe in all working environments; they are installed and operated as any other industrial machine tool. Class 1 laser systems do not require the use of any special laser safety equipment by operators or bystanders during their normal operation.

Class 4 laser marking systems do not incorporate protective enclosures. Extra precautions are required.

The Labelase®28XX Tag Printer complies with Class 1 during normal use because of the numerous interlocks provided as detailed in section II.

During service and/or alignment the Labelase®28XX Tag Printer becomes a Class 4 device. Servicing should be performed only by a **Qualified Laser Service/Safety Technician!** Because of the Class 4 classification, InfoSight will provide such a person to be available to the end user of this marker.

The nominal power output of the laser used is 60,80 or 100 watts, with a maximum peak power output of 110 watts. It is a CO₂ infrared (invisible) laser with a wavelength of 10.57 to 10.63 microns. The radiant energy and the wavelength are less than Class 1 requirements during normal operation.

Section II: Types of safety interlocks.

There are several types of safety features provided on the InfoSight Labelase® 28XX Tag Printer:

Type 1 includes **Mechanical Switches**. These switches are located atop the marker and on the rear of the marker. These switches remove power supplied to the laser marker, as shown in electrical drawings.

- Switch A -- Large Red, easily accessible, E-STOP operator Emergency Stop Push Button.
- Switch B -- Key switch

Type 2 includes **Optical Sensors**. Sensors monitor whether tag material is in place and the marker is able to move the tag material. These two sensors are monitored by the marking microprocessor.

Type 3 includes **Mechanical Design**. Here, narrow slots are provided to minimize the release of laser radiation. The beam path from laser tube to final pass through lens is entirely enclosed in a metal shield, with suitable material that will absorb the heat produced by the beam emitting from the CO₂ laser.

Type 4 includes **Password Security Access**. The Software requires a **supervisor password** to change layout of tags or to alter the operating parameters of the marker itself.

The features and precautions described above are designed with the safety of the user in mind. Should you have any questions or suggestions please contact InfoSight directly.

Laser Safety

The features above and precautions described above taken by InfoSight are in place with the safety of the user in mind. Should you have any questions or suggestions please do not hesitate to call.

INTERNAL LASER SPECIFICATIONS (60 WATT)

Laser Type.....	60 watt CO ₂ pulsed wave
Laser Classification.....	Class IV during service (Title 21 CFR, Part 1040 U.S., FDA)
Wave Length	10.57 to 10.63 microns
Power Output:	
Typical.....	60 watts (@ 5kHz)
Minimum on delivery.....	45 watts (@ 5kHz)
End of life	40 watts (@ 5kHz)
Power Stability.....	after 30 sec. warm-up: ±5%
Mode	TEM ₀₀ equivalent - 95% purity
Beam size.....	3.5mm
Divergence (mR).....	5
Polarization.....	Random
Modulation.....	to 5 kHz
Pulse Repetition frequency	5 kHz
Electrical Control.....	TTL input (+3.5 V) to 20 kHz
Electrical Input.....	48 VDC version (Firestar TI80) 28-32 VDC, 16A max
Tickle pulse.....	1.0 μS (@ 5kHz)
Thermal shutdown temperature	140° F ± 2.7°F, 60° C ±1.5°C
Laser tube life expectancy	35,000 hrs.
Laser shelf life (no use).....	14 years

INTERNAL LASER SPECIFICATIONS (80 WATT)

Laser Type.....	80 watt CO ₂ pulsed wave
Laser Classification.....	Class IV during service (Title 21 CFR, Part 1040 U.S., FDA)
Wave Length	10.57 to 10.63 microns
Power Output:	
Typical	80 watts (@ 5kHz)
Minimum on delivery	60 watts (@ 5kHz)
End of life	50 watts (@ 5kHz)
Power Stability	after 30 sec. warm-up: ±5%
Mode	TEM ₀₀ equivalent - 95% purity
Beam size.....	3.5mm
Divergence (mR).....	5
Polarization.....	Random
Modulation.....	to 5 kHz
Pulse Repetition frequency	5 kHz
Electrical Control.....	TTL input (+3.5 V) to 20 kHz
Electrical Input	28 VDC version (48-2-28) 48 VDC version (Firestar TI80) 28-32 VDC, 16A max
Tickle pulse.....	1.0 μS (@ 5kHz)
Thermal shutdown temperature	140° F ± 2.7°F, 60° C ±1.5°C
Laser tube life expectancy	35,000 hrs.
Laser shelf life (no use).....	14 years

INTERNAL LASER SPECIFICATIONS (100 WATT)

Laser Type.....	100 watt CO ₂ pulsed wave
Laser Classification.....	Class IV during service (Title 21 CFR, Part 1040 U.S., FDA)
Wave Length	10.57 to 10.63 microns
Power Output:	
Typical	110 watts (@ 5kHz)
Minimum on delivery	100 watts (@ 5kHz)
End of life	70 watts (@ 5kHz)
Power Stability	after 30 sec. warm-up: ±5%
Mode	TEM ₀₀ equivalent - 95% purity
Beam size.....	3.5mm
Divergence (mR).....	5
Polarization.....	Random
Modulation.....	to 5 kHz
Pulse Repetition frequency	5 kHz
Electrical Control.....	TTL input (+3.5 V) to 20 kHz
Electrical Input	28 VDC version (48-2-28) 48 VDC version (Firestar T1100) 28-32 VDC, 16A max
Tickle pulse.....	1.0 μS (@ 5kHz)
Thermal shutdown temperature	140° F ± 2.7°F, 60° C ±1.5°C
Laser tube life expectancy	35,000 hrs.
Laser shelf life (no use).....	14 years

LASER SPECIFICATIONS:

Type of laser	60,80 or 100 watt CO ₂ PULSED WAVE (RF Excited)
LASER Classification	Class I During normal operation
Wave length	10.6 microns
Mode	TEM ₀₀ 95% purity
Polarization	Linear-vertical 50:1 extinction min.
Pulse Repetition frequency	5 kHz
Emergent beam size	3.5 mm
Divergent beam size	
Tickle pulse	1.0 us @ 5 kHz
Power Supply	30vdc @ 16/32 amps/10,25,50watt 48vdc @ 28 amps / 60/80/100 watt
Laser Tube life expectancy	>20,000 hours
Thermal shutdown	50 degrees C

DECLARATION OF CONFORMITY
InfoSight Corporation

20700 US Highway 23 Chillicothe, Ohio 45601
+1.740.642.3600 TEL +1.740.642.5001 FAX

InfoSight hereby declares the equipment specified conforms to the Classification(s), Directive(s) and Standard(s) set forth in this document.

InfoSight produces laser systems within one of two classes as identified and classified by the CDRH. These are Class I and Class IV. (see CDRH 21 CFR (J) 1040.1 - 1040.5). End user of the equipment should be familiar with ANSI, CDRH and OSHA standards for radiation emitting devices as they apply to them also.

ANSI Z136.1 - 1993

We will provide adequate data to the LSO (Laser Safety Officer) enabling LSO to designate NHZ (nominal hazard zone) as required pursuant to Class IV 3.4.1

CDRH 21 CFR (J) 1040.1 1040.5

OSHA Publication 8-1.7
Section II Chapter 6

Certifications:

EMC Emissions

- ICES-003 Issue 4 Class A Digital Apparatus emissions requirements (Canada)
- CRF47 FCC Part 15 Subpart B Class A emissions requirements (USA)
- EN55011:2007/A2:2007 Group 1 Class A ISM emissions requirements (EU)
- EN61000-3-2:2006 Limits for harmonic current emissions
(equipment input current up to and including 16A per phase)
- EN61000-3-3:2008 Limitation of voltage fluctuations and flicker in low-voltage supply systems
for equipment with rated current up to and including 16A
- EN61326:2006, ICES-003 (230 V configuration only)
EMC requirements for Electrical equipment for measurement, control
and laboratory use – General Use

Name and Publication Date of Standard Used to Evaluate Laser safety:

IEC 60825—1:2007 (2nd Edition)

Safety

- IEC 61010-1:2001 and EN6100-1:2001
Including Group and National differences as they apply for AU, CA, US, CH, JP, and KR
- IEC 60825-1:2007 (2nd Edition)

Note: InfoSight design guidelines are drawn from ANSI and CDRH



1.1.1 LL2800 DECLARATION OF CONFORMITY

Declaration of conformity
Konformitätserklärung
Déclaration de conformité
Declaración de Confomidad
Verklaring de overeenstemming
Dichiarazione di conformità

We/Wir/ Nous/WIJ/Noi: **InfoSight Corporation**
20700 US Rt 23
Chillicothe, Ohio 45601 USA

declare under our sole responsibility that the product,
erklären, in alleniniger Verantwortung, daß dieses Produkt,
déclarons sous notre seule responsabilité que le produit,
declaramos, bajo nuestra sola responsabilidad, que el producto,
verklaren onder onze verantwoordelijkheid, dat het product,
dichiariamo sotto nostra unica responsabilità, che il prodotto,

LL2800

to which this declaration relates is in conformity with the following standard(s) or other normative documents.
auf das sich diese Erklärung bezieht, mit der/den folgenden Norm(en) oder Richtlinie(n) übereinstimmt.
auquel se réfère cette déclaration est conforme à la (aux) norme(s) ou au(x) document(s) normatif(s).
al que se refiere esta declaración es conforme a la(s) norma(s) u otro(s) documento(s) normativo(s).
waarnaar deze verklaring verwijst, aan de volende norm(en) of richtlijn(en) beantwoordt.
a cui si riferisce questa dichiarazione è conforme alla/e seguente/i norma/o documento/i normativo/i.

EMC Emissions:

EMC Emissions

- ICES-003 Issue 4 Class A Digital Apparatus emissions requirements (Canada)
- CFR 47 FCC Part 15 Subpart B class A emissions requirements (USA)
- EN 55011:2007/A2:2007 Group 1 Class A ISM emissions requirements (EU)
- EN 61000-3-2:2006 Limits for harmonic current emissions
(equipment input current up to and including 16A per phase)
- EN 31000-3-3:2008 Limitation of voltage fluctuations and flicker in low-voltage supply systems for
equipment with rated current up to an including 16A

EMC Immunity:

- EN 61326:2006 EMC requirements for Electrical equipment for measurement, control and
laboratory use – General Use

Safety

- IEC 61010-1:2001 and EN6100-1:2001
Including Group and National differences as they apply for AU, CA, US, CH, JP, and KR
- IEC 60825-1:2007 (2nd Edition)

Edward S. ONeal
2/15/2013
Chillicothe, Ohio

ENGINEERING DRAWINGS