

Weigh Measure Stencil (WMS) Systems



InfoSight designs and integrates fully-automated WMS solutions—custom-designed to match your product length and diameter range and your in-conveyor or lateral transfer geometry.

System Options

- Weight measurement $\pm 0.1\%$ accuracy and repeatability is typical
 - ⇒ Options to weigh lateral transfer pipe, or linear-movement pipe in conveyor are available
- Length measurement ± 0.05 ft / ± 15 mm (1/2 of API tolerance) is typical
 - ⇒ Options to measure lateral transfer pipe, or linear movement pipe in conveyor are available
- Colorband (optional) - 3 spray nozzles / 5 colors is standard—more possible per your specification
- Stencil marking - Ink jet technology - 16 dot resolution - 150 - 1.25" (32mm) characters is standard - more possible. API and UF logos are standard. Custom logos are programmable.
- Stamp marking (optional) – PinStamp® technology - 30 - 0.25" (6.4mm) or 40-3/16" (4.8mm) - 5x7 or 7x9 dot matrix characters is standard, more possible
- Pipe-by-Pipe production report with time, length, weight, message data for each pipe
- Tally report totalizes length and weight for both GOOD and REJECT pipe
- Designed specifically for industrial pipe and tube mill applications
- Rugged construction—using proven technologies
- InfoSight, and our predecessor Telesis, have been building WMS Systems since 1979

WE BARCODE DIFFICULT STUFF. ®

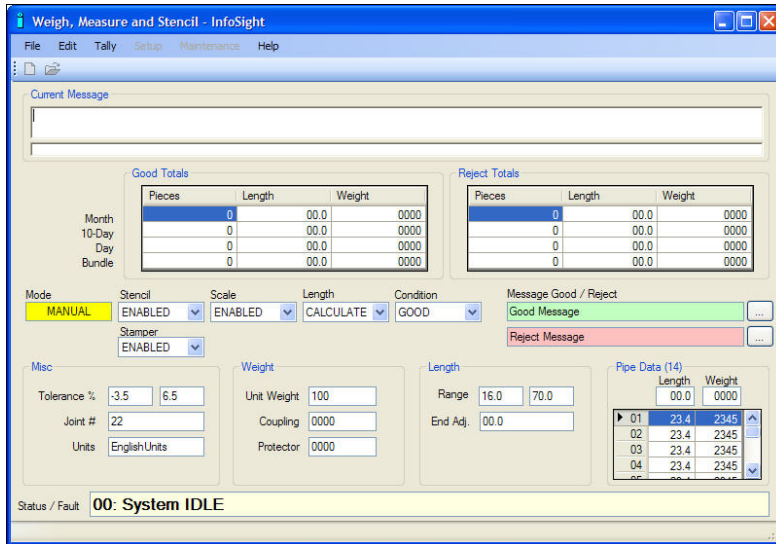

WMS Operating Screen
(Can be translated to a different language)

- Current messages are displayed for both stencil and stamp
- Real-time GOOD and REJECT Length and Weight Totals are displayed—totalized by bundle, day, 10-Day and Month
- API Weight/Length tolerance error-checking is performed—with programmable \pm tolerance limit values
- Length range error-checking is performed—with programmable min/max allowable length values
- Arbitrary operator-REJECT of any pipe is possible
- All checking / REJECT operations enable auto-marking of REJECT message for REJECT condition
- Automatic joint numbering is possible
- English or Metric units can be selected
- End treatment (couplings, end protectors) - automatic weight and length adjustment is possible to include or not include end treatment

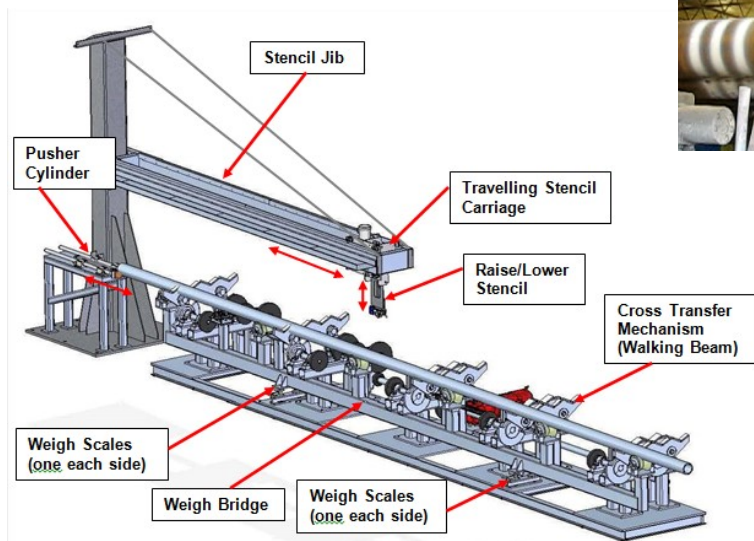
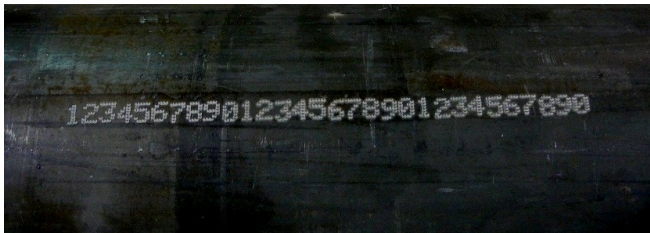

Example WMS with walking beam pipe transfer